

Conversion of voltmeter to ammeter and vice-versa

Objective

- Convert a given voltmeter to an ammeter of suitable range and calibrate the ammeter so prepared.
- Convert a given (micro or milli) ammeter to a voltmeter of suitable range and calibrate the ammeter so prepared.

Apparatus

Voltmeter, (micro or milli) Ammeter, resistance boxes ($1\Omega - 10k\Omega$ and fractional), wires, digital voltmeter and milli-ammeter or multimeter, power supply (0–5 volt).

Working Theory

Voltmeter measures voltage drop across resistance by putting it in parallel to the resistance as shown in Fig 1. The internal resistance of a voltmeter is quite high ($R_m \gg R$) and, therefore, when connected in parallel the current through the voltmeter is quite small ($i_v \approx 0$). This keeps the current i_r flowing through the resistance R almost the same as when the voltmeter was not connected. Hence, the voltage drop ($i_r R$) measured across the resistance by a voltmeter is also almost the same as the voltage drop without the voltmeter across the resistance.

On the other hand, ammeter measures current through resistance by connecting it in series with the resistance, Fig 1. An ammeter has very low resistance ($R_m \ll R$) and changes the effective resistance of the circuit only by a tiny amount ($R + R_m \approx R$), not altering the original current by too much. Therefore, the current measured by the ammeter is about the same as without the ammeter in the circuit.

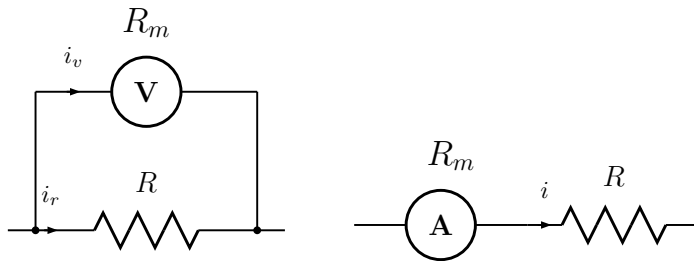

Fig 1. Schematic diagram of voltmeter and ammeter connections

Conversion of voltmeter to ammeter

Since the internal resistance of a voltmeter is much greater than ammeter, for conversion to ammeter we need to decrease the voltmeter's internal resistance by adding appropriate *shunt* i.e. resistance in parallel to the meter. Let the range of the voltmeter be $0 - V_0$ volt and we convert it to an ammeter of range $0 - I_0$ Amp.

To calculate the shunt resistance, we need to know the resistance of the voltmeter. This is done by *half-deflection* (potential divider) method using the circuit shown in

Fig 2(a). Let R_m be the internal resistance of the voltmeter, and when $R = 0$ the voltmeter reading is V_m , the current through the circuit is $i = V_m/R_m$. But when $R \neq 0$ and the voltmeter reads $V_m/2$, the current in the circuit reduces by half implying $i/2 = V_m/(R + R_m)$. The voltmeter resistance R_m is given by,

$$\frac{V_m}{2R_m} = \frac{V_m}{R + R_m} \Rightarrow \boxed{R_m = R} \quad (1)$$

Once R_m is determined, the shunt R_{sh} can be determined by noting that, to get full-scale reading V_0 of the voltmeter we need a maximum current of $I_m = V_0/R_m$. For full-scale reading of voltmeter V_0 corresponding to full-scale reading I_0 of our constructed ammeter, we need to send a current I_m through the voltmeter and the remaining I_{sh} through the shunt. Therefore the shunt resistance R_{sh} , the maximum resistance that can allow minimum I_{sh} current, is calculated as,

$$I_{sh} = I_0 - I_m \Rightarrow \boxed{R_{sh} = \frac{V_0}{I_{sh}}} \quad (2)$$

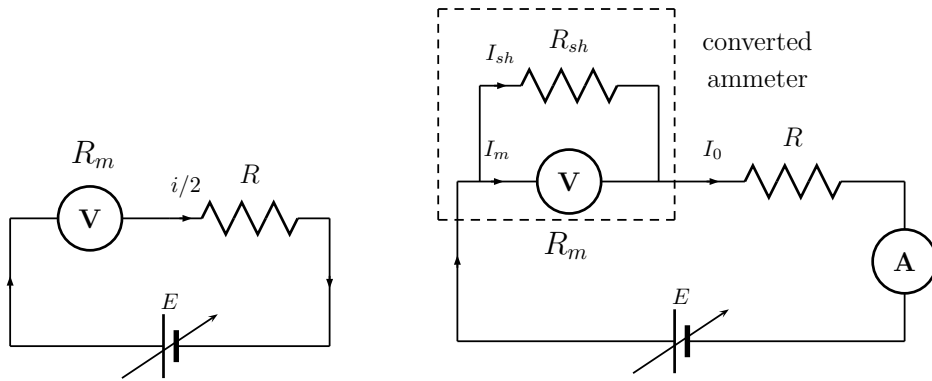

Fig 2. (a) Circuit for determination of voltmeter resistance, (b) circuit for using the voltmeter as ammeter.

Conversion of ammeter to voltmeter

Converting an ammeter to a voltmeter involves increasing the resistance of the ammeter. This is done by adding a high resistance in series with the ammeter. Let the range of the ammeter be $0 - I_0$ Amp and we convert it to a voltmeter of range $0 - V_0$ volt.

To calculate the series resistance R_{ss} , we first determine the ammeter resistance using the circuit Fig 3(a). Let R_m be the internal resistance of the ammeter, then the current flowing through the circuit is $i = E/(R + R_m)$, where E is the input voltage. The voltage drop across R is V_r and the current is $i_r = V_r/R$. Since $i = i_r$, the ammeter resistance R_m is obtained as,

$$\boxed{R_m = \frac{(E - V_r) R}{V_r}} \quad (3)$$

To calculate R_{ss} we note that the voltage drop across the ammeter, showing full scale reading I_0 , is $V_m = I_0 \times R_m$. To make ammeter full-scale to read full-scale voltage V_0 , the remaining voltage $V_{ss} = V_0 - V_m$ should drop across R_{ss} and from this consideration we calculate series resistance as,

$$\frac{V_{ss}}{R_{ss}} = \frac{V_m}{R_m} \implies \boxed{R_{ss} = R_m \frac{V_{ss}}{V_m}} \quad (4)$$

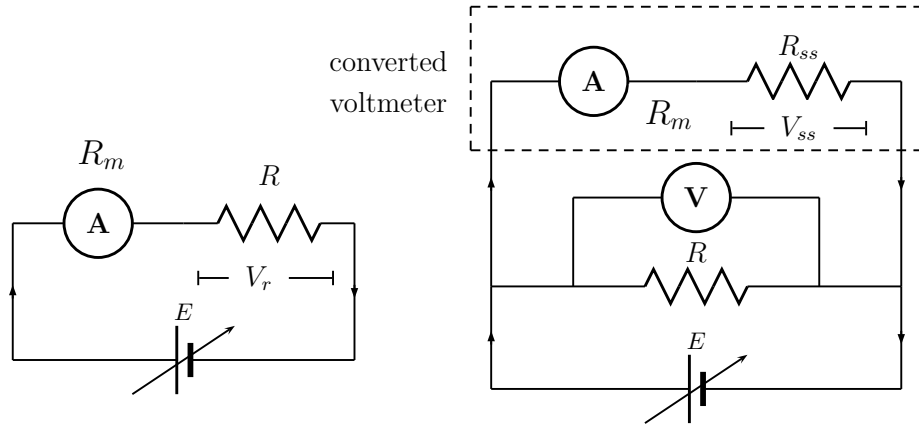

Fig 3. (a) Circuit for determination of ammeter resistance, (b) circuit for using the ammeter as voltmeter.

Experimental procedure

1. The first step to convert a voltmeter to an ammeter is to determine the resistance R_m of the voltmeter. Make the circuit connections as shown in Fig 2(a).
2. Keeping $R = 0$, adjust the supply voltage E so that the voltmeter shows large readings V_m .
3. Choose suitable R to reduce the voltage recorded in voltmeter to half, $V_m/2$. The voltmeter resistance is then $R_m = R$. You may choose to plot the R_m against serial numbers and draw an average line through them to obtain the average R_m .
4. Calculate the shunt resistance R_{sh} and fabricate the circuit shown in Fig 2(b). Use a digital ammeter or a multimeter, set to appropriate range, as the standard ammeter.
5. Changing the supply voltage for a fixed R (chosen such that the maximum current in the circuit is little above I_0), record the converted and the standard ammeter readings I_{new} and $I_{standard}$.
6. Plot the calibration curve $I_{new} - I_{standard}$ versus $I_{standard}$.

7. Begin converting an ammeter to a voltmeter by determining the resistance R_m of the ammeter. Make the circuit connections as shown in Fig 3(a). The resistance R in series with the ammeter must be kept at large value to prevent large current from flowing through the ammeter and damaging it.
8. Change R appropriately and each time measure the voltage drop across it V_r with a digital voltmeter or a multimeter. Also change the supply voltage E to change the V_r . Calculate R_m from these set of readings either by direct averaging or by plotting R_m versus serial number and drawing an average line.
9. Calculate the series resistance R_{ss} and fabricate the circuit as shown in Fig 3(b). Use a digital voltmeter or a multimeter, set to appropriate range, as the standard voltmeter.
10. Changing the supply voltage for a fixed R (chosen such that the maximum voltage in the circuit is little above V_0), record the converted and the standard voltmeter readings V_{new} and V_{standard} .
11. Plot the calibration curve $V_{\text{new}} - V_{\text{standard}}$ versus V_{standard} .

Data recording and Observations

Converting voltmeter volt to ammeter Amp

Full-scale reading of the voltmeter = volt

Number of divisions in the scale =

Value of minimum division of the voltmeter = volt

Full-scale reading of the converted ammeter = Amp

Number of divisions in the scale =

Value of minimum division of the converted ammeter = Amp

Table 1. Measurement of voltmeter resistance R_m

Serial No.	Full deflection		Half deflection		R_m Ohm	Average R_m Ohm
	V_m volt	R Ohm	$V_m/2$ volt	R Ohm		
...	0
...	0	
...	0	
...	0	
...	0	

Calculation of R_{sh} :

$$I_m = V_0/R_m = \dots\dots \text{Amp}$$

$$I_{sh} = I_0 - I_m = \dots\dots \text{Amp}$$

$$R_{sh} = V_0/I_{sh} = \dots\dots \text{Ohm}$$

Table 2. Calibration of the converted Ammeter

Converted ammeter I_{new} Amp	Standard ammeter I_{standard} Amp	Correction $I_{\text{new}} - I_{\text{standard}}$ Amp
.....
.....
.....

Converting Ammeter Amp to Voltmeter volt

Full-scale reading of the ammeter = Amp

Number of divisions in the scale =

Value of minimum division of the ammeter = Amp

Full-scale reading of the converted voltmeter = volt

Number of divisions in the scale =

Value of minimum division of the converted voltmeter = volt

Table 3. Measurement of ammeter resistance R_m

Serial No.	E volt	R Ohm	V_r volt	$R_m = (E - V_r)R/V_r$ Ohm	Average R_m Ohm
...
...	
...	
...	
...	

Calculation of R_{ss} :

$$V_m = I_0 \times R_m = \dots\dots \text{ volt}$$

$$V_{ss} = V_0 - V_m = \dots\dots \text{ volt}$$

$$R_{ss} = R_m V_{ss} / V_m = \dots\dots \text{ Ohm}$$

Table 2. Calibration of the converted Voltmeter

Converted voltmeter V_{new} volt	Standard voltmeter V_{standard} volt	Correction $V_{\text{new}} - V_{\text{standard}}$ volt
.....
.....
.....